

Accompanying Device Documentation

Programmable PID multichannel temperature controller



MRF-2-004-A ..

MRH-4-007-A ..



The device has to be mounted, connected and parameterized according to the user manual no. 104781 (for plant engineering companys). All herein indicated Safety Instructions must be strictly observed!

The user manual is available on the Internet at www.welba.de/pdf-englisch/ba/104781.pdf. You can request a printed version at Welba.

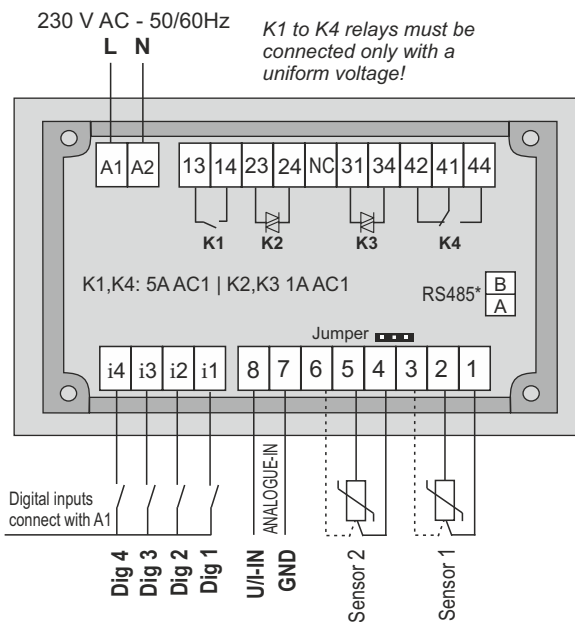

Items supplied

- Controller
- Holder (only at MRF-2..)
- Rubber seal
- Fixing screws

Unpacking and storage

If the packaging is damaged or something is missing, do not fit the temperature controller. In this case please contact Welba.

If you keep the temperature controller for a period before using it, store it in a clean dry place.

Jumper positions:

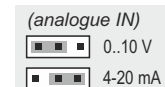

The plant engineering company must prepare operating instructions for the operator, taking account of the controller's parameters as supplied.

We recommend referring only to the parameters which the end user needs for safe operation.

In preparing the operating instructions for the end user, especially the chapter on "Safety", account must be taken of local regulations.

Technical data

Operating voltage	230 V AC - 50/60 Hz
Relay contact (potential free)	2 changeover contacts, 2 make contacts max. switching current 5 AAC1
Semiconductor relay max. switching voltage	2 pcs. - max. switching current 1AAC 1 230 V AC
Display	13 mm LED display, 3 digits
Display range	-99 to 999
Number of sensor inputs	2
Useable sensors	KTY 81-110 KTY 81-210 PT 100 (2- or 3- wires) PT 1000
Measure range (depending on the sensor used)	
- KTY 81-110	-50° to +150°C
- KTY 81-210	-50° to +150°C
- PT 100 (2 or 3 wires)	-99° to +400°C
- PT 1000	-99° to +400°C
Analog input	switchable via jumper
- Voltage 0-10 V	Ri => 50 kOhm
- Current 4-20 mA	Ri =< 100 Ohm
Digital inputs	4 (via opto coupler)
Interface RS-485	WE-BUS / MOD-Bus (depending on the version)
Temperature alarms	2 (independently)
Control mode	two step / three step control PID pulsed
Hysteresis	0,1 K to 99,9 K freely adjustable
Housing MRF-2 (Front panel mount.)	- Front size 106 x 68 mm - Front panel cut 87 x 56 mm
Housing MRH-2 (Rear wall mount.)	- Overall dimension 108 x 80 mm - Front panel cut 87,2 x 66,2 mm build-in-appliance - installation depth 45 mm
Installation conditions	
Protection class	
- Housing front	IP 64
- Rear	IP 00
Electrical safety	Overvoltage category II
Pollution degree	2
Rated impulse voltage	1500V
Connection	Plug-in screw connections for cables up to 2,5 mm ² / 1,5 mm ²
Environment specifications:	
- Operation temperature	0° .. +50°C
- Storage temperature	-20° .. +70°C
- max. humidity	75% (no dew)

105541D/E - Technical data subject to change. 05.02.2020