



Measuring - Controlling - Regulating  
All from the same source

welba.de

## Temperature regulator MPR-A2

Installation and operating instructions  
for plant engineering companies



---

## Content

Function . . . . .	Page 2
Intended use . . . . .	Page 3
Safety . . . . .	Page 3
Installation . . . . .	Page 4
Dimensions and techn. data regulator . . . . .	Page 6
Dimensions and techn. data sensor (accessory) . . . . .	Page 6
Operating regulator . . . . .	Page 7
Examples of use . . . . .	Page 7
Notes for programing of the regulator . . . . .	Page 10
Parameter settings in general . . . . .	Page 11
Working level operation . . . . .	Page 11
Programming level operation . . . . .	Page 12
Configuration level operation . . . . .	Page 13
Description of the input functions . . . . .	Page 15
Setting the actual value correction . . . . .	Page 15
Fault indication on the display . . . . .	Page 16
General measures when using electronic control systems . .	Page 17

---

## Function



The microprocessor-controlled temperature regulator of the series MPR-A2 are used to control heating and cooling processes.

The regulator unit has three relay contacts to control the compressor, heaters, alarms, fans, etc.

The measured temperature of the medium is permanently displayed. If this temperature deviates from the selected target temperature by the hysteresis value, the appropriate relay contact is activated.

The operation and the default values of the regulator are subdivide in three parameter levels. The assessment for each level is configurable by the assemblyman.

At the first operating level the working level a button can be pressed to display and change the target temperature set for relay contact K1. (The alter of the target temperature for the operating level can be looked.)

## Intended use

**These operating instructions contain important technical and safety information.**

**Please read carefully before installation and before any work on or with the regulator.**

The microprocessor-controlled temperature regulator type MPR-A2 is used to control heating and cooling systems, alarm devices, fans, etc.

Any other use of the device is permitted only with prior written permission from the manufacturer.

The microprocessor controller can be used after the parameters has been adjusted if it is used the first time. To get start the controller without the adjustments is not igneous and can destroy the facility or the medium which temperature has to be controlled.

The device is fitted with a resistance temperature sensor. The output ports are designed as potential-free relay ports.

The device must not be installed in potentially explosive atmospheres.

**CE** The microprocessor-controlled temperature regulator type MPR-A2 meets the EC requirements for electromagnetic compatibility (EMC) and complies with the "low voltage" directive (LVD).

The safety components meet the VDE regulations.

## Safety



**The temperature regulator may only be installed by an authorised specialist, observing all local safety requirements.**

**Only specialists must be allowed to access the environment when connected.**

**The temperature regulator contains live components and must not be opened.**

**The device must not be used if the housing or the connection terminals are damaged.**

**No liquids must penetrate the housing.**

**The temperature regulator may be exported to the USA with the permission of the manufacturer only.**

## Installation

- a. It is essential not to install the device under the following conditions:
- severe jolting or vibration
  - permanent contact with water
  - relative humidity of more than 90%
  - sharply fluctuating temperatures (condensation)
  - aggressive atmospheres (ammonia or sulphur fumes).  
Risk of oxidation.
  - operation in the immediate vicinity of radio transmitters with increased levels of spurious radiation.

b. Housing installation

The housing is mounted using two lateral screw fittings.

- Fit the rubber seal as shown
- Place the housing through the front opening.
- Attach the lateral screw fittings.
- Tighten the screws.

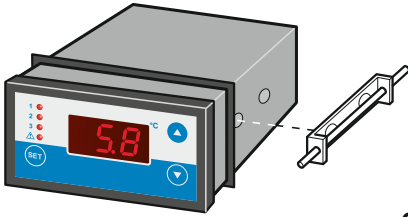

c. Installing the sensor



**The sensor cable must not be chafed or kinked.**



**There must be no substantial mechanical pressure on the sensor tube.**

**Do not place the sensor and the power cable in the same cable conduit.**

Note on sensor type

The MPR-A2 is designed for operation with PT-1000 sensors.

The different sensor types can be visually distinguished as follows:

	black	= KTY 81-210 or PT-100
	red	= PT-1000

After finishing the electrical connections the regulator must be adjusted in the parameter "Sensor correction" [C91] that the measured temperature is equal with the value on the display. Therefore it must be used a reference thermometer.

See the section "Setting the actual value correction" on page 15.

d. Electrical connection



**Before connecting, ensure that the mains voltage is the same as indicated on the device's type plate.**

**Incorrect electrical connection can cause damage to the regulator and to the equipment.**

**The mains voltage should not be switched on until all components including the sensor are connected.**

**When connecting appliances (or loading the relay contacts) with currents of >10A AC1, it is essential to fit contactors.**

**Downstream contactors must be fitted with an RC protection circuit. (see also page 17).**

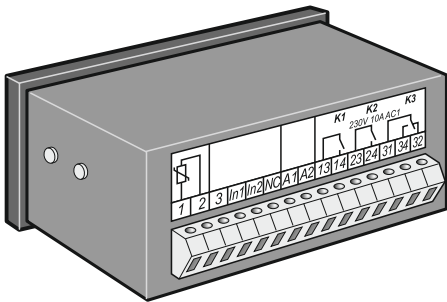

You will find the circuit diagram for your regulator on the back of the housing, above the connection terminals..

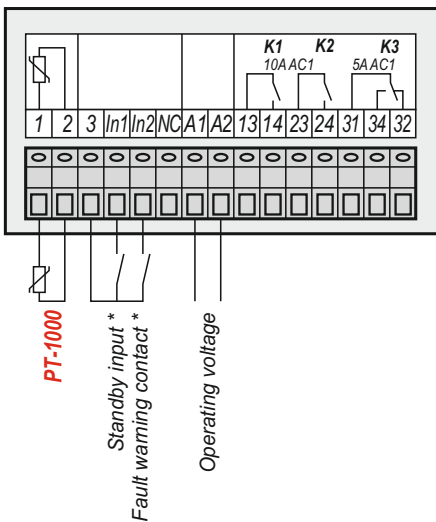

The electrical connection procedure is as follows:

- Connect heating and cooling systems in accordance with the appropriate circuit diagram.
- Connect alarm devices, fans, etc.
- Connect mains supply leads.

Observe the following tips:

- Use cable bushes.
- Make sure that cables cannot chafe.

\* See also description of the input functions on page 15.

## Dimensions and technical data regulator

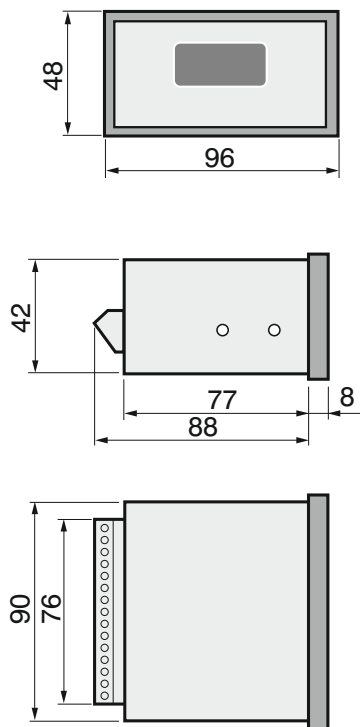

Operating voltage	110 .. 240 V AC, 50/60 Hz oder 24 V AC/DC	
Relay contacts	2 voltage-free make-contact 1 voltage-free two-way-contact	
Max. switching current	K1, K2 = 10 AAC1 K3= 5 AAC1	
Max. switching voltage	- 230V - 24V	250 V ~ 30 V ~
Display	13 mm LED display, 3 digits	
Display range	- range -9,9 .. 99,9°C - other	0.1°C 1.0°C
Control type	Two-step regulator	
Measurement range	-9,9 to 120	
Usable sensor types	PT-1000	
Hysteresis	0.1 K to 30 K freely adjustable	
Operation	Heating/cooling interchangeable each switch setting	
Housing	NEG 48/96 M	
- front dimension	- 96 x 48 mm	
- front-panel cut-out	- 42 x 90 mm	
- installation depth	- 88 mm	
Protection (housing front)	IP 64	
Pollution level	Conductive dirt must not get into the interior of the housing	
Connection	Screw terminals	
Ambient temperature	-20° to +70°C	
- operating temperature	0° to +50°C	
- storage temperature	75% (no condensation)	
- max. humidity		

Technical facts with reservation.

## Dimensions and technical data sensor

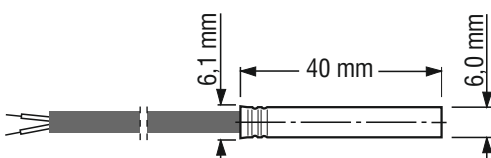

Sensor element	PTC sensor, KTY 81-210
Bush material	1.4301(V2A)
Bush length	40 mm
Bush diameter	6.0 mm +/- 0.1
Cable material	- PVC (standard) - Silicon (special model)
Cable length	standard 2 metres

## Operating regulator

The regulator operates at three levels:

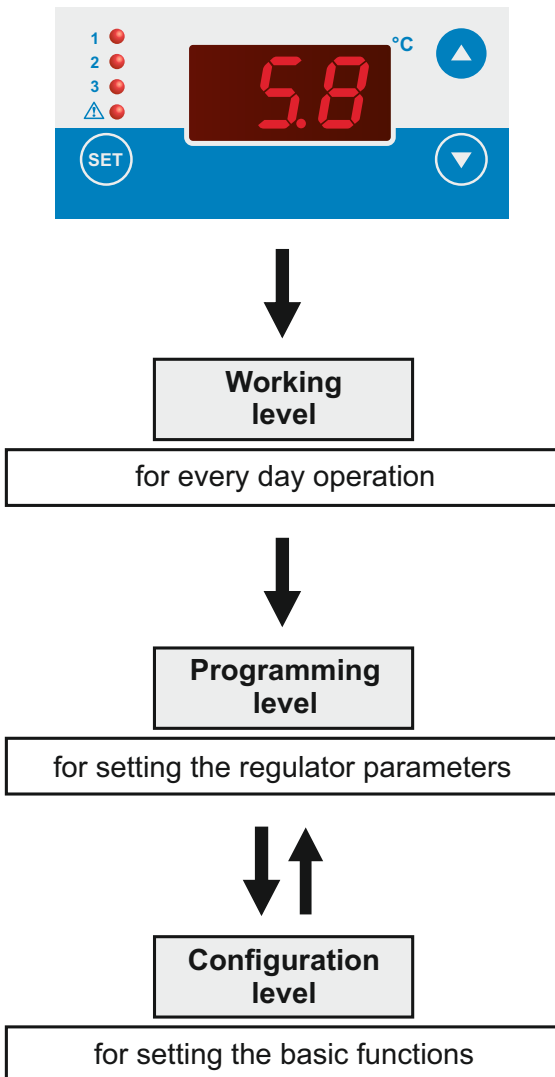

### Working level:

....for everyday operation by the end user.

The present temperature of the medium as measured is permanently displayed.

Press the SET button to see the target temperature set for output port relay K1. Press the up-arrow or down-arrow key as the same time as the SET button to adjust the target temperature.

NB: The target temperature can be adjusted here only if the programming level button lock [C99] is set to "0"

### Programming level:

This is the level at which the regulatory parameters are set.

Setting is more complex and possible only using specific combinations of buttons so as to prevent accidental changes to settings.

### Configuration level:

This is the level at which the basic functions of the regulator are set. As subsequent interventions by the end user (after the parameters have been set) can result in dangerous changes to functions which might not be immediately obvious, access to the configuration level is even more complex.

### Important:

When programming the target temperatures for the various appliances that are connected, take account of which target temperature the end user is most likely to need to adjust. Regardless of the number of switching stages, only the target temperature for output relay K1 can be directly adjusted at working level.

## Examples of use

The MPR-A2 series of microprocessor controlled regulators are very versatile: They can be used to control up to three appliances (heating, cooling or alarm systems).

The following examples show two possible uses and the appropriate parameter settings.

**Example 1: MPR-A2 (three-point regulation)  
to control a cooling and heating system**

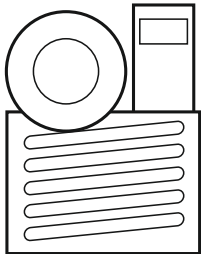
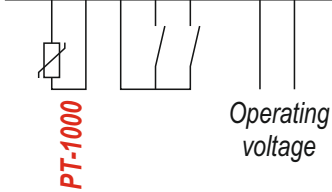
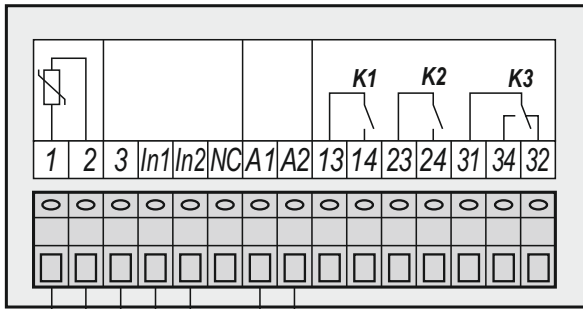

**K1**  
Cooling

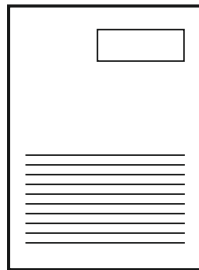

**K2**  
Heater

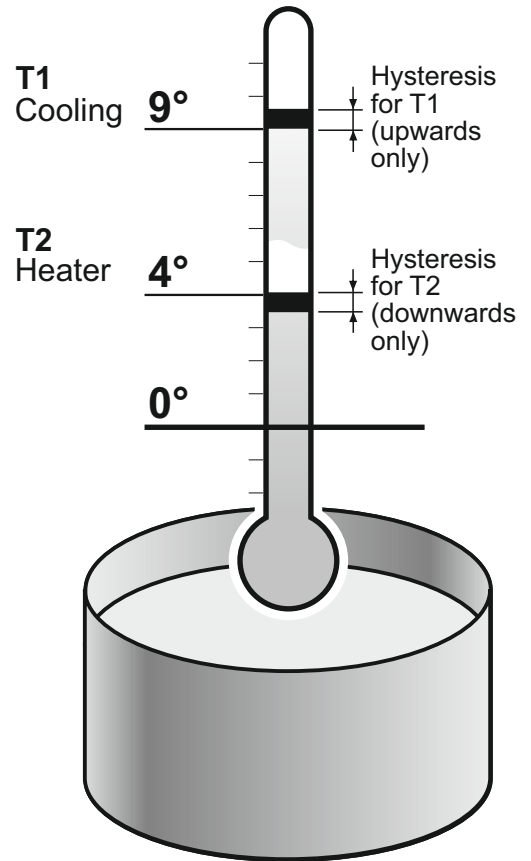

A medium has to be maintained at a temperature of between 9°C and 4°C. The deviation must not exceed 0.5K.

A cooling and a heating system is to be used (three point regulation). Proceed as follows:

**Programming level:**

- Set parameter for target-temperature 1 [C1] to 9°C
- Set parameter for target-temperature 2 [C2] to 4°C
- Set hysteresis parameter for target-temp. 1 [C20] to 0.5K
- Set hysteresis parameter for target-temp. 2 [C21] to 0.5K

**Configuration level:**

- Set switch direction parameter for relay K1 [P1] to 1 (cooling contact)
- Set switch direction parameter for relay K1 [P2] to 0 (heating contact)
- Set parameters for function K1 and K2 for sensor failure [P10+P11] as desired
- Set hysteresis mode parameter for target 1 [P15] to 1 [mono-direction]
- Set hysteresis mode parameter for target 2 [P16] to 2 [mono-direction]
- Set the remaining parameters as desired

**Operation**

- If the temperature of the medium rises to 9.5°C, cooling is switched on, and then switched off again at 9°C
- If the temperature of the medium falls below 3.5°C, heating is switched on, and then switched off again at 4°C



## Example 2: MPR-A2

to control of two cooling systems, a heating system and a alarm system

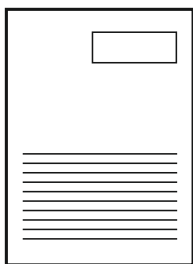
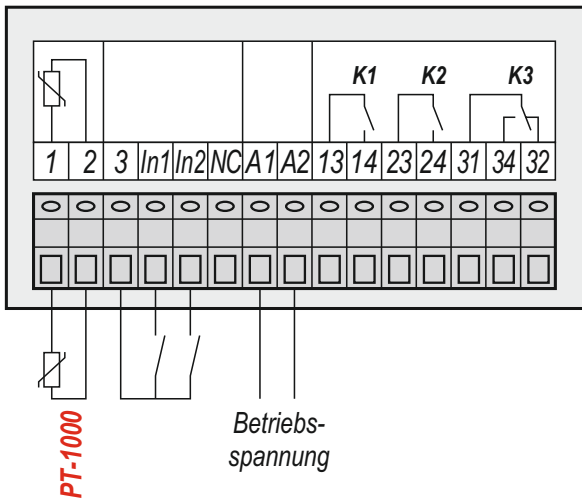

**K1**  
Heater

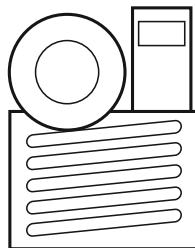

**K2**  
Cooling

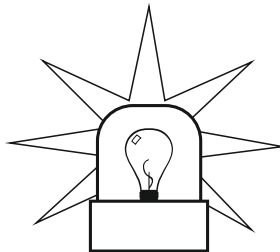

**K3**  
Alarm

### Caution:

The device is programmed so that the target temperature for heating can be changed at working level.

This is why the heating system is connected to relay contact K1.

A medium is to be maintained at a temperature of between 13°C and 6°C. The permissible temperature deviations are controlled by the hysteresis settings.

The temperature is to be controlled by a cooling system - a heating system will prevent the temperature from falling below 6°C.

An additional alarm is to be activated at 3°C

Proceed as follows:

Programming level:

- Set parameter for target temperature 1 [C1] to 6°C
- Set parameter for target temperature 2 [C2] to 10°C
- Set parameter for target temperature 3 [C3] to 3°C
- Set hysteresis parameter for target-temp. 1 [C20] to 0.6K
- Set hysteresis parameter for target-temp. 2 [C21] to 0.8K
- Set hysteresis parameter for target-temp. 3 [C23] to 0.1K

See next page.

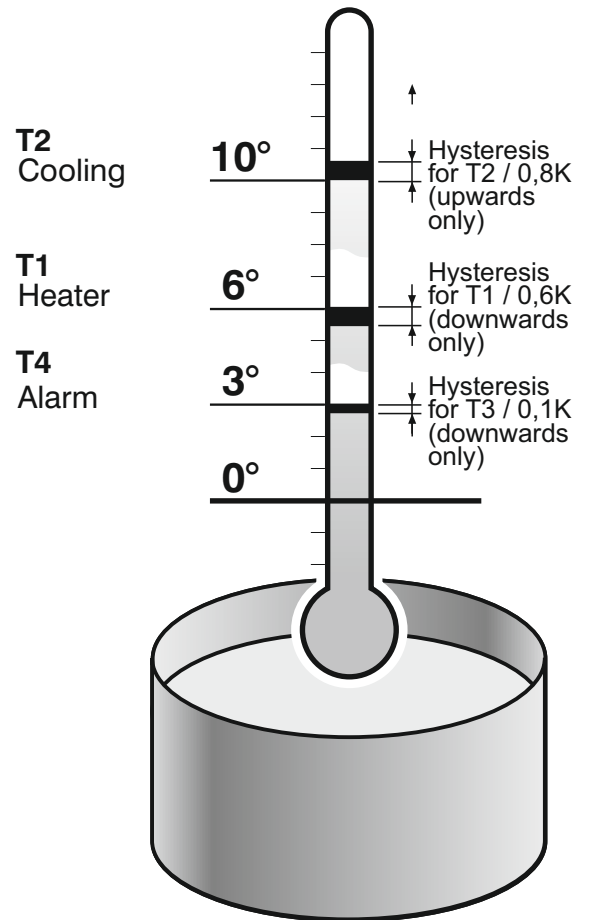

#### Configuration level

- Set switching direction param. for K1 [P1] to 0 (heating contact)
- Set switching direction param. for K2 [P2] to 1 (cooling contact)
- Set switching direction param. for K3 [P4] to 0 (heating contact)
  
- Set parameters for functions K1 to K3 for sensor failure [P10-P12] as desired
  
- Set hysteresis mode parameter for target 1 [P15] to 1 (mono-directional)
- Set hysteresis mode parameter for target 2 [P16] to 1 (mono-directional)
- Set hysteresis mode parameter for target 3 [P17] to 1 (mono-directional)  
Mono directional hysteresis mode means:
  - switching direction for cooling contact: hysteresis upwards
  - switching direction for heating contact: hysteresis downwards
  
- Set the remaining parameters as desired

#### Operation:

- If the temperature of the medium rises to 10.8°C, cooling system 1 is switched on, and then switched off again at 10°C.
- If the temperature of the medium falls below 5.4°C, the heating system is switched on, and then switched off again at 6°C.
- If the capacity of heating system is not sufficient, and the temperature continues to fall below 2.9°C, the alarm is triggered and continues until the temperature rises above 3.0°C.

---

## Notes for programming of the regulator

Before starting operation, all pre-set parameters should be adjusted to suit local conditions. Wrongly set parameters can have a serious effect on functions.

All steps required to program the controllers are described below.

#### Important:

We recommend recording details of the settings before delivery to your customer. In this way you will be able to supply spare regulators pre-set.

When replacing a regulator, the only adjustment to be made at the end user's premises will then be the actual value correction.

## Parameter settings in general



To adjust a parameter, proceed as follows:

- Select parameter (on pressing the SET button, the present value will be displayed).
- Holding the SET button down, simultaneously press the up-arrow or down-arrow until the desired value is reached.
- Tip: Holding the arrow down longer changes the value more quickly.
- Release the SET button.

### Switch back to working level

(possible from every parameter)

- Press up-arrow and down arrow simultaneously for about 5 seconds.

The current actual value appears in the display.

(If, at programming or configuration level, no buttons are pressed for about 1 minute, the regulator switches back to working level automatically.)

## Working level operation

The working level is for everyday operation by the end user. The display permanently shows the present temperature of the medium as measured.

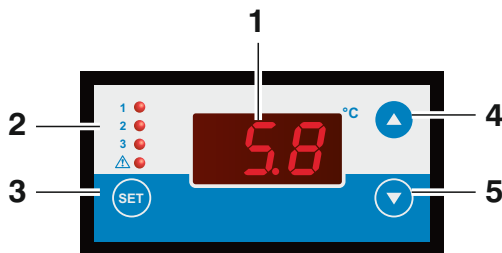

Button	Function
1	Display (the measured temperature of the medium is permanently displayed.)
2	LED 1 - Display "Relay contact K1" LED 2 - Display "Relay contact K2" LED 3 - Display "Relay contact K3" These show when the corresponding relay contact is activated. ----- LED 4 - Display "Fault warning system" flashes when the fault signaling contact is closed.
3	Press SET button: Display the target temperature set for relay contact K1
4*	Press up-arrow together with SET button: Increases target temperature for relay contact K1
5*	Press down-arrow together with SET button: Reduces target temperature for relay contact K1

\* (See also "button lock" parameter at programming level)

## Programming level operation



The programming level is for setting the regulator parameters. Access to this level is more complex in order to avoid accidental resetting of the values by the end user.

Switching to programming level:

- Press up-arrow and down-arrow simultaneously for approx. 5 seconds, until [C1] appears in the display.
- Press up-arrow or down arrow until you reach the parameter you want adjust.

## Meaning of parameters

### Operating diagram programming level

Switch to programming level =

Press simultaneously for approx. 5

	Show setting	Change setting	
		Press SET button	Press SET button and  or  simultaneously
Target temperature 1	[C1] 	SET	+  or
Target temperature 2	[C2] 	SET	+  or
Target temperature 3	[C3] 	SET	+  or
Hysteresis for target temperature 1	[C20] 	SET	+  or
Hysteresis for target temperature 2	[C21] 	SET	+  or
Hysteresis for target temperature 3	[C22] 	SET	+  or
Current actual value	[C90] 	SET	+  or
Sensor correction	[C91] 	SET	+  or
Software version	[C98] 	SET	+  or
Button lock	[C99] 	SET	+  or

Switch back to working level =

Press simultaneously for approx. 5 seconds (Switches back automatically after approx. 1 minute if no further buttons are pressed).

**Parameter C1: Target temperature for K1**

**Parameter C2: Target temperature for K2**

**Parameter C3: Target temperature for K3**

The target temperature is the temperature at which the corresponding relay contact is to be activated.

**Parameter C20: Hysteresis for target-temp. 1**

**Parameter C21: Hysteresis for target-temp. 2**

**Parameter C22: Hysteresis for target-temp. 3**

The hysteresis determines the value by which the temperature of the medium may deviate from the corresponding target temperature before the relay contact is activated. See sketch.

If the contact in question is for cooling, the hysteresis is always higher. In the case of heating contacts it is below the target temperature. (cooling or heating contact is set at configuration level).

In the "symmetrical" hysteresis mode, the value selected is distributed on both sides of the target temperatures.

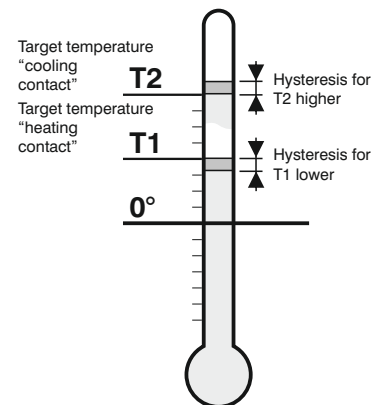

**Parameter C90: Current actual value**

Setting reference temperature. See page 15.

**Parameter C91: Actual value correction**

A correction can be made to the value as measured by the sensor, which applies cumulatively over the entire measuring range.

See the section "Setting the actual value correction" on page 15.

**Parameter C98: Installierte Software-Version**

Display of the installed software version. Serves for communication with the service technician.

**Parameter C99: Button lock**

This can be used to prevent adjustment of the target temperature for outlet port relay K1 in the working level.

0 = Buttons not locked

1 = buttons locked

# Configuration level operation



This level is for configuring the regulator's basic functions.

**To prevent interference by the end user, access is made even more complex.**

### Switching to configuration level:

- Press up-arrow and down-arrow simultaneously for approx. 5 seconds, until [C1] appears in the display.
- Press button "Arrow UP" repeatedly until the last parameter [C99] at working level is reached.
- Press button "Arrow UP" again and hold down until [Pb] appears in the display.
- When [Pb] appears, hold down button "Arrow UP" and simultaneously press button "Arrow DOWN" for approx. 3 seconds. The display then shows the first parameter [P1] in the configuration level.

## Operating diagram configuration level

Switching to configuration level: see description

		Show setting	Change setting
		Press SET button	Press SET button and $\Delta$ or $\nabla$ simultaneously
Switching direction K1	P 1	SET	+ $\Delta$ or $\nabla$
	$\Delta$		
Switching direction K2	P 2	SET	+ $\Delta$ or $\nabla$
	$\Delta$		
Switching direction K3	P 3	SET	+ $\Delta$ or $\nabla$
	$\Delta$		
Sensor failure function K1	P 10	SET	+ $\Delta$ or $\nabla$
	$\Delta$		
Sensor failure function K2	P 11	SET	+ $\Delta$ or $\nabla$
	$\Delta$		
Sensor failure function K3	P 12	SET	+ $\Delta$ or $\nabla$
	$\Delta$		
Hysteresis mode for 1	P 15	SET	+ $\Delta$ or $\nabla$
	$\Delta$		
Hysteresis mode for 2	P 16	SET	+ $\Delta$ or $\nabla$
	$\Delta$		
Hysteresis mode for 3	P 17	SET	+ $\Delta$ or $\nabla$

### Meaning of parameters

- Parameter P1: Switching direction relay K1**
- Parameter P2: Switching direction relay K2**
- Parameter P3: Switching direction relay K3**

The switching direction can be set as a heating or cooling contact for each individual relay contact.

- 0 = Heating contact
- 1 = Cooling contact

- Param. P10: Function K1 in event of sensor failure**
  - Param. P11: Function K2 in event of sensor failure**
  - Param. P12: Function K3 in event of sensor failure**
- The switching status of the relay contacts can be set for the event of a sensor failure.

- 0 = OFF in the event of failure
- 1 = ON in the event of failure

- Param. P15: Hysteresis mode target temp. 1**
- Param. P16: Hysteresis mode target temp. 2**
- Param. P17: Hysteresis mode target temp. 3** (with reference to the compressor relay)

- 0 = symmetrical
- 1 = one-sided

## Operating diagram configuration level

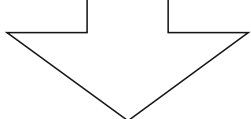

## Operating diagram configuration level

		Show setting	Change setting
		Press SET button	Press SET button and $\Delta$ or $\nabla$ simultaneously
Limit for T1 downwards	P 20	SET	+ $\Delta$ or $\nabla$
	$\Delta$		
Limit for T1 upwards	P 21	SET	+ $\Delta$ or $\nabla$
	$\Delta$		
Limit for T2 downwards	P 22	SET	+ $\Delta$ or $\nabla$
	$\Delta$		
Limit for T2 upwards	P 23	SET	+ $\Delta$ or $\nabla$
	$\Delta$		
Limit for T3 downwards	P 24	SET	+ $\Delta$ or $\nabla$
	$\Delta$		
Limit for T3 upwards	P 25	SET	+ $\Delta$ or $\nabla$
	$\Delta$		
Limit for hysteresis 1 downwards	P 30	SET	+ $\Delta$ or $\nabla$
	$\Delta$		
Limit for hysteresis 1 upwards	P 31	SET	+ $\Delta$ or $\nabla$
	$\Delta$		
Limit for hysteresis 2 downwards	P 32	SET	+ $\Delta$ or $\nabla$
	$\Delta$		
Limit for hysteresis 2 upwards	P 33	SET	+ $\Delta$ or $\nabla$
	$\Delta$		
Limit for hysteresis 3 downwards	P 34	SET	+ $\Delta$ or $\nabla$
	$\Delta$		
Limit for hysteresis 3 upwards	P 35	SET	+ $\Delta$ or $\nabla$
	$\Delta$		
Min. action time K1	P 50	SET	+ $\Delta$ or $\nabla$
	$\Delta$		
Min. pause time K1	P 51	SET	+ $\Delta$ or $\nabla$
	$\Delta$		
Min. action time K2	P 52	SET	+ $\Delta$ or $\nabla$
	$\Delta$		
Min. pause time K2	P 53	SET	+ $\Delta$ or $\nabla$
	$\Delta$		
Min. action time K3	P 54	SET	+ $\Delta$ or $\nabla$
	$\Delta$		
Min. pause time K3	P 55	SET	+ $\Delta$ or $\nabla$
	$\Delta$		

Switch back to working level =

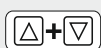

Press simultaneously for approx. 5 seconds  
(Switches back automatically after approx.  
1 minute if no further buttons are pressed).

**Parameter P20: Limit for target temp. 1 downwards**  
**Parameter P21: Limit for target temp. 1 upwards**  
**Parameter P22: Limit for target temp. 2 downwards**  
**Parameter P23: Limit for target temp. 2 upwards**  
**Parameter P24: Limit for target temp. 3 downwards**  
**Parameter P25: Limit for target temp. 3 upwards**  
 Setting of input limits for target temperatures at working and programming levels.  
 Range: -9,9 .. +110°C

**Parameter P30: Limit for hysteresis 1 downwards**  
**Parameter P31: Limit for hysteresis 1 upwards**  
**Parameter P32: Limit for hysteresis 2 downwards**  
**Parameter P33: Limit for hysteresis 2 upwards**  
**Parameter P34: Limit for hysteresis 3 downwards**  
**Parameter P35: Limit for hysteresis 3 upwards**  
 Setting of input limits for hysteresis at programming level.  
 Range: -0,1 .. +30 K

**Parameter P50: Minimum action time for relay K1**  
**Parameter P51: Minimum pause time for relay K1**  
**Parameter P52: Minimum action time for relay K2**  
**Parameter P53: Minimum pause time for relay K2**  
**Parameter P54: Minimum action time for relay K3**  
**Parameter P55: Minimum pause time for relay K3**  
 Setting of minimum action time or minimum pause time for relay contacts, in order to prevent repeated switching on and off.  
 Range: 0.0 .. 999 seconds

## Description of the input functions

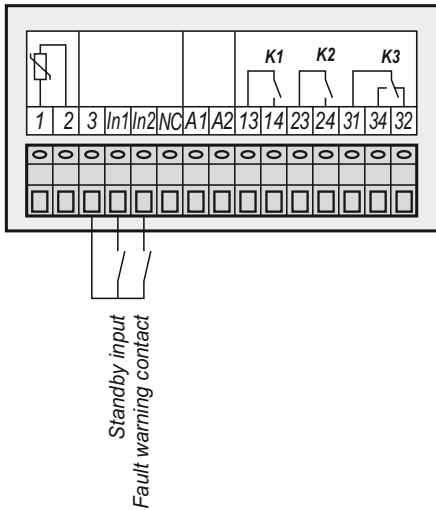

### Standby funktion

If the digital input “In1” is connected,

- the controller switches to standby
- all relay outputs are switched off
- “Stb” appears in the display

### Fault warning function

If the digital input “In2” is connected,

- the fault message LED flashes to indicate the fault

The fault warning system has no influence on the relays.  
The fault warning system is deactivated in standby.

## Setting the actual value correction

A correction can be made to the value as measured by the sensor, which applies cumulatively over the entire measuring range.

This is necessary when:

- the length of the sensor cable is changed, or
- a faulty sensor is replaced, giving rise to an incorrect reading.

In order to adjust the actual value correction, a reference thermometer is needed.

Proceed as follows:

- Install sensor.
- Measure the media temperature using the reference thermometer.
- Switch on the control and set parameter [C90] to the determined temperature.

The control calculates the difference value between the reference thermometer and temperature sensor 1 and automatically sets this in parameter [C91].

The parameter [C91] can be displayed and adjusted at any time.

- Hold down the up and down arrow keys at the same time:  
The settings are saved

## Fault indication on the display



Faults in the temperature regulator are indicated by a flashing display as follows:

LED - Display	Fault
F1	<b>Sensor short circuit:</b> The sensor or sensor cable is faulty and must be replaced or repaired. Parameter [C91] "Actual value correction" must then be adjusted at programming level.
F2	<b>Broken sensor:</b> The sensor or sensor cable is faulty and must be replaced or repaired. Parameter [C91] "Actual value correction" must then be adjusted at programming level.
EEP	<b>Memory fault:</b> Invalid memory areas were detected. See section: "EEP fault message"
FFF	<b>Measurement range exceeded:</b> The maximum measurement range of the sensor has been exceeded.

### Fault message EEP => memory fault:

When switching on, the control checks whether the parameter values in the E-prom memory have been changed inadmissibly. In rare cases, this is possible due to EMC effects or, for example, lightning strikes. If an impermissible change has been detected, "EEP" is shown on the display => the control is not ready for operation.

Method:

- Press and hold the SET button until "dEF" appears in the display: The standard configuration (factory setting) has been restored.
- Press the SET button again to confirm the factory reset.
- Reset the original parameterization for the tank and save it.

## General measures when using electronic control systems

So that even complicated regulatory tasks can be presented to the user in a manner which is clear and simple and ensures high measurement accuracy, today's electronic control systems make increasing use of microprocessors. However, the benefits of these systems are countered by the disadvantage that increased measurement accuracy is accompanied by sensitivity to interference. In order to minimise the effect which interference may have on the regulator, the user also must take account of a number of points when installing a new regulator.

Assistance here is provided by standard DIN VDE 0843 on the electromagnetic compatibility (EMC) of measurement, control and regulatory devices in industrial process technology. The following table shows, for example, the maximum interference levels to which, according to the standard, an appliance may be exposed.

<i>Degree of severity</i>	<i>Environment class</i>	<i>Test voltage Power supply</i>	<i>Test voltage Signal/control line</i>
1	well-protected environment	0.5 kV	0.25 kV
2	protected environment	1.0 kV	0.5 kV
3	typical industrial environment	2.0 kV	1.0 kV
4	Industrial environment with very high interference level	4.0 kV	2.0 kV

As the values given in the table are maximum values, operational values should remain well below them. However, in practice this is possible only with difficulty, as even a normal contactor without interference suppression produces interference pulses of up to 3.0 kV. For this reason we recommend that the following principles be taken into account during installation:

- a. Try to eliminate all sources of interference, by carrying out interference suppression and minimising the interference level. Radio interference suppression is required under VDE 0875, and confirmed by VDE 0874. In principle, interference must be eliminated at source. The nearer the interference suppresser is to the source of interference, the greater its effect.

Interference spreads through wires or by electromagnetic radiation. It is usually the former which interferes most seriously with regulation systems.

Possible interference sources (to name but a few) include:

- bouncing contacts when switching loads
- switching off inductive loads (contactors, motors, solenoid valves, etc.)
- unsatisfactory routing of wires, too small cross-sections
- loose contacts
- rhythmically changing power stages (power converters)
- power breakers
- high-frequency generators

- b. If specific interference sources cannot be avoided, they should at least be kept at a distance from the regulator system.
- c. Capacitive and inductive couplings can cause crosstalk between high-voltage lines and parallel low-voltage and sensor lines. This distorts measured values and signals and can disrupt the entire regulatory process. It is therefore recommended that all sensors and signal lines be placed separately from the control and mains voltage lines.
- d. If possible, a separate mains line should be provided to feed the regulator system. This helps reduce any interference penetrating the regulator via the mains supply line. Voltage surges resulting from switching substantial loads will also then be less of a problem.
- e. In the case of contactors, solenoid valves and other inductive consumers, the induction voltage occurring during switching has to be reduced by appropriate protection methods. The choice of methods depends on whether the consumer runs on DC or AC voltage.

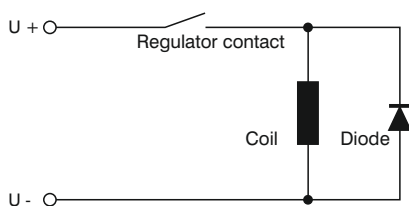

- *DC voltage*

In the case of d/c voltage systems, the induction voltage occurring can, for example, be limited by using self-induction diodes, varistors or suppresser diodes. The diagram on the left shows one possibility using a self-induction diode.

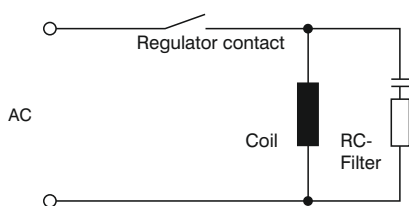

- *AC voltage*

In the case of a/c voltage, interference suppression as described above is not possible. Instead, an RC combination must be used. An RC filter must be connected as directly as possible to the inductance, in order to ensure a short line. In addition, the component ratings of the RC combination must be geared to the inductance. Too low ratings lead to excessive voltage, and too high ratings cause significant losses in the interference suppresser component. Another point to note here is that only capacitors which meet VDE 0656 may be used. They must be suited to the mains voltage and designed for very high switching voltages. The diagram on the left shows inductance interference suppression using an RC filter.

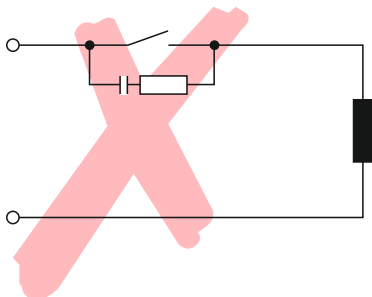

An RC filter should not be fitted directly to the regulator's switching contact, as shown on the left, as an idle current will flow through the RC combination even when the switching contact is open. This current may be enough to mean that a downstream contactor is not de-energised and a closed protective contact does not reopen.

- f. Semiconductor switches such as thyristors or triacs also produce interference voltages. They occur as a result of non-linear characteristics and finite ignition voltages. These components must be protected against excessive voltages, for which mainly varistors, RC combinations or choke coils are used. The use of zero-voltage switches is also recommended.

The suggestions made represent only a few of the possible ways of protecting a microprocessor-controlled regulator system from interference. The suggested measures have the advantage that they will increase the lifetime of the devices, as lower induction voltages (reduced spark formation) will also reduce contact burn.