



## Universal tank control WTS-100-2

Installation and operating instructions  
for plant engineering companies



WTS-100-2 G1

WELBA GmbH  
Electronic Control Engineering  
Gewerbepark Siebenmorgen 6  
D-53547 Breitscheid

Phone: +49 (0)2638 / 9320-0  
Fax: +49 (0)2638 / 9320-20  
E-mail: [info@welba.de](mailto:info@welba.de)  
Net: [www.welba.de](http://www.welba.de)

Appliance description . . . . .	3
Intended use . . . . .	5
Safety . . . . .	5
Installation . . . . .	6
Disposal . . . . .	7
Technical data of regulator . . . . .	9
Sensor dimensions and technical data . . . . .	9
Operating levels . . . . .	10
Operation of working levels . . . . .	11
Washing programme description . . . . .	15
Adjustment of parameters in general . . . . .	20
Operation of 'General cooling parameters' level . . . . .	21
Operation of 'Extended cooling parameters' level . . . . .	23
Operation of 'General washing parameters' level . . . . .	25
Operation of 'Extended washing parameters' level . . . . .	28
'Intermediate stirring' options in cooling mode . . . . .	30
'Continuous stirring' function . . . . .	30
Sensor correction procedure . . . . .	31
Adjustment of level control . . . . .	31
Fault indication on the display . . . . .	32
General measures when using electronic control systems . . . . .	33
Circuit diagram WTS-100-2-A G1 . . . . .	36



The WTS-100-2 is a universal tank control unit combining a modern milk cooling regulator and a complete washing programme control system in one.

The control unit has various operating modes:

- **OFF mode (tank empty)**

The control unit is on stand-by. The display shows 'OFF', the LEDs are out and all output relays are deactivated..

The following operating modes can only be selected from the OFF mode. It is not possible to switch directly from one of them to another.

**CAUTION: The control unit is live even when switched off.**

- **Cooling mode**

The current milk temperature, as measured, is permanently displayed.

It is possible to switch between two freely adjustable target temperatures by pressing a button. If the milk temperature exceeds the selected target temperature (T1 or T2) by the hysteresis value, the compressor relay and agitator are automatically activated. Once the target temperature is reached, the compressor switches off, while the agitator continues to operate for the pre-set 'after-stirring' time.

During non-cooling periods the agitator switches on at pre-set intervals in order to ensure an even temperature throughout the milk.

Independently of this a short or long 'intermediate stirring' period can be selected during cooling by pressing a button.

Operate by pressing button on foil keyboard:

If the delayed start is activated (parameter c80), cooling starts for the first milking after a delay. If the cooling button is pressed twice, cooling starts immediately.

Operation via digital input:

The cooling starts immediately - depending on the setting in parameter C79 - or with a delayed start cooling.

- **Continuous stirring mode**

The agitator can be switched on from the OFF-mode by pressing a button and press OFF-button to switch off [C85] = '0'. In parameter [C85] it can be adjusted at what time the agitator will switch off. This action can be discontinued at any time with the OFF-button.

When [C85] is set to '0' the agitator is running indefinitely, but can be switched off with the OFF-button at any time.

- **Washing mode**

The washing timer controls water intake as either by time or level, selected. All running times (heater, pump, detergent injection) can be set separately. Detergent switchover from acidic to alkaline can also be set.

The WTS-100-2 controls the various processes and times needed for a thorough wash fully automatically.

**Following a power failure the control unit restarts in the mode in which it was operating before the outage.**



**These operating instructions contain important technical and safety information.**

**Please read carefully before installation and before any work on or with the regulator.**

The universal tank control type WTS-100-2 is used to control heating and cooling systems, alarm devices, fans, etc.

Any other use of the device is permitted only with prior written permission from the manufacturer.

The universal tank control is ready for use once the parameters have been set. It should not be used before this has been done as this might result in damage to the plant and the item to be cooled or heated.

The device is fitted with a resistance temperature sensor.



The device must not be installed in potentially explosive atmospheres.

The universal tank control type WTS-100-2 fulfils the EC requirements for electromagnetic compatibility (EMC) and the Low Voltage Directive (LVD).

The safety components meet the VDE regulations.



**The universal tank control must be installed by an authorised specialist observing local safety regulations.**

**Access to the environment when connected must be restricted to specialised personnel.**

**The universal tank control contains live components and must not be opened up.**

**It must not be used if the housing or connection terminals are damaged.**

**No fluids must penetrate the housing.**

**The universal tank control may not be exported to the USA without the manufacturer's express permission.**

It is essential not to install the device under the following conditions:

- severe jolting or vibration
- permanent contact with water
- relative humidity of more than 90%
- sharply fluctuating temperatures (condensation)
- operation in an aggressive atmosphere (ammonia or sulphur fumes) - risk of oxidation
- operation in the immediate vicinity of radio transmitters with high levels of spurious radiation.

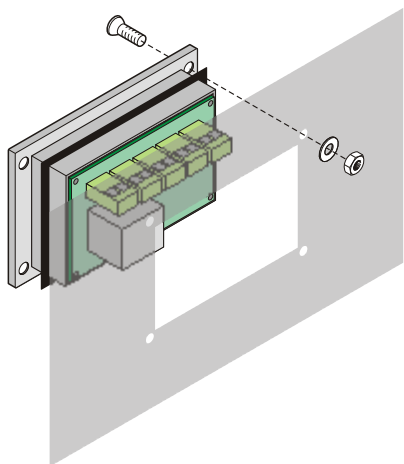

## Installation of housing

For fixing the housing please follow the instructions:

- Place the seal carefully in the groove. Ensure it is not twisted.
- Insert the housing from the front through the switchboard cut-out and fasten using the screws provided.
- Carry out the electrical wiring and sensor connection in accordance with the following description.

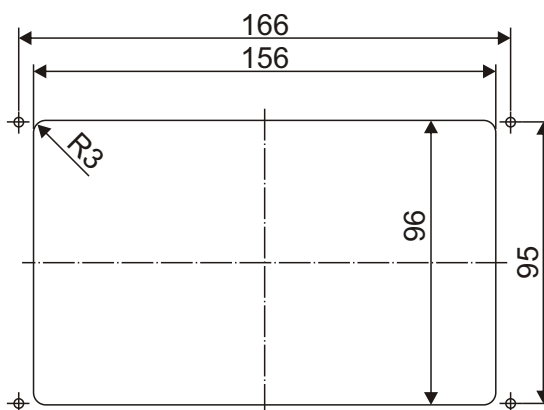

Drilling diagram

## Fitting the sensor



**The sensor cable must not be chafed or kinked.**

**There must be no substantial mechanical pressure on the sensor tube.**

**Do not place the sensor and the high-voltage cable in the same cable conduit (not even within the switchbox).**

**Temperature range sensor cable -10°C .. +70°C**

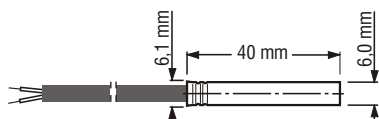

## Changing the sensor cable length

If it is necessary to shorten or lengthen the sensor cable on installation (or if a sensor other than the one supplied is to be fitted), the "actual value correction" parameter must be adjusted accordingly. See the section "Setting the actual value correction" on page 31.



### Electrical connection

**Before connecting ensure that the mains voltage is the same as indicated on the device's type plate.**

**Incorrect electrical connection can cause damage to the tank control and to the equipment.**

**The mains voltage should not be switched on until all components including the sensor are connected.**

**No appliances with current levels in excess of the maximum values indicated on the relays should be connected to the relay contacts**

**Use contactors.**

**Downstream contactors must be fitted with an RC protection circuit. (see also page 33).**



You will find the circuit diagram for your tank control on the back of the housing above the connection terminals.

## Disposal



For the purposes of disposal, the device is classified as waste electronic equipment within the meaning of European Directive 2002/96/EC (WEEE) and must not be included with household waste. It must be disposed of through the correct channels.

Local and current legislation must be observed.

## Connection diagram

- Electrical connections must be as shown in the diagram below.
- Use cable bushes.
- Make sure that cables cannot chafe.
- Observe relay current rating.
- In all cases use contactors for pump, compressor and heater.
- Do not feed digital inputs with external voltage! Use potential-free switches.

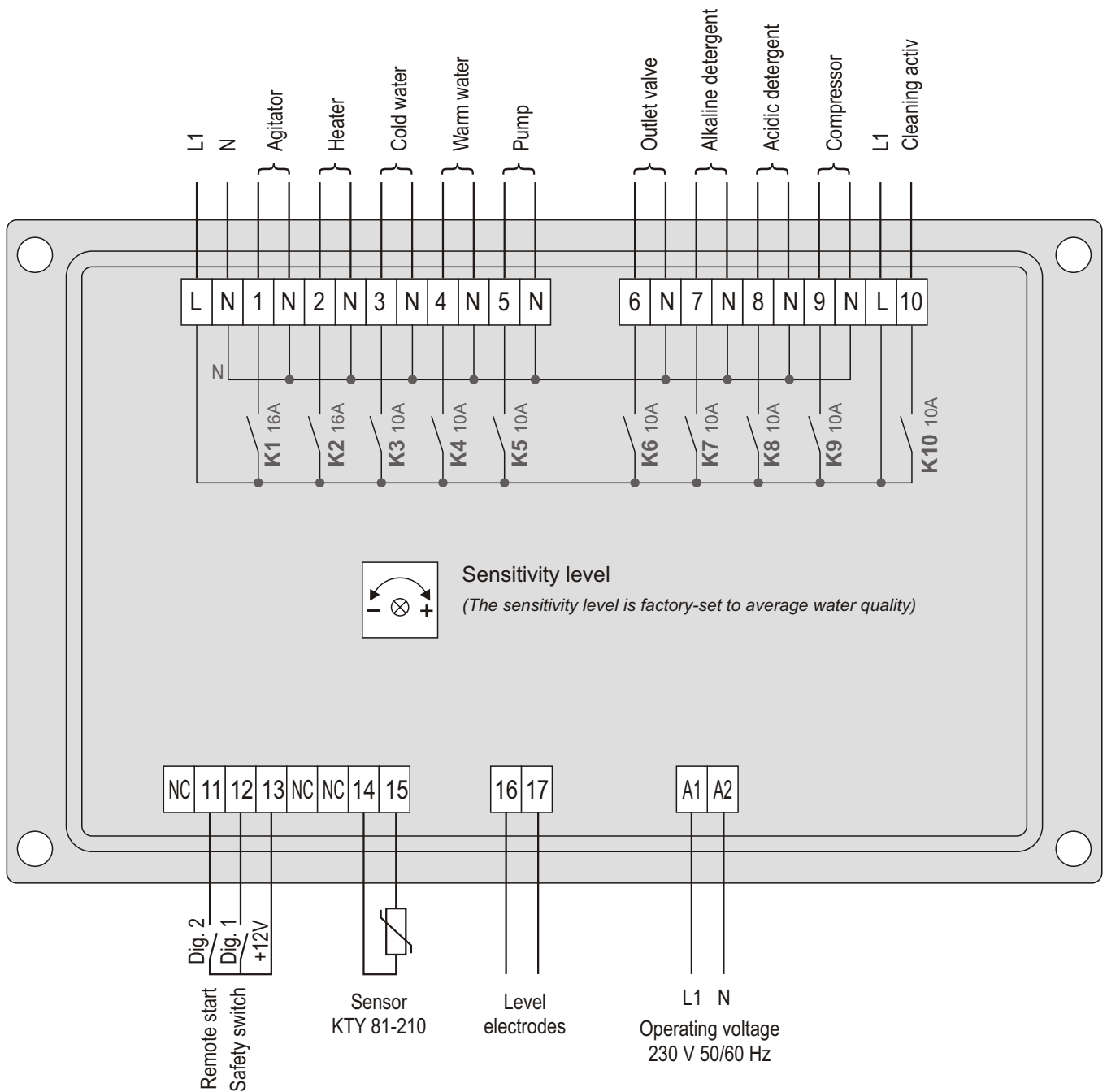

## Technical data tank control



Operating voltage	230V AC +N +PE, 50/60 Hz
Relay contacts	10 make-contacts
max. switching current	8 x each 10A AC1 - 250V AC 2 x each 16A AC1 - 250V AC
max. switching voltage	250V AC - 50..60 Hz
Display	13 mm LED - Display, 3 digits
LED switching status displays	3 mm
Display range	-99 .. 999
Number of Sensors	1 or 2
Sensor type	KTY 81-210
Sensor cable length	2 metres (or as required)
Measurement range	-5° .. +70°C
Temperature resolution	0,1°C
Control mode	two-step-controller
Hysteresis*	0,1 K .. 99,9 K (standard adjusting 0,7 K)
Water recognition	via 2 electrodes (optional)
Target temperature T1*	standard adjusting 8°C
Target temperature T2*	standard adjusting 4°C
Digital inputs	3 (via optocoupler)
Connection	Plug-in screw connections for cables up to 2.5 mm <sup>2</sup>
Housing - front dimension - front panel cut out - insertion depth	FEG 106/175 M 106 x 175 mm 156 x 96 mm 45 mm
Protection (housing front)	IP 65
Environment specifications: - Operation temperature - Storage temperature - max. humidity	0° .. +50°C -20° .. +70°C 75% (no dew)

Technical data subject to changes.

## Sensor dimensions and technical data

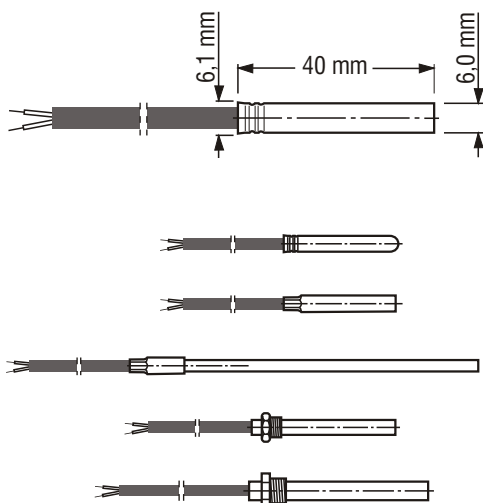

Sensor element	KTY sensor
Bush material	1.4301(V2A)
Bush length	40 mm
Bush diameter	6.0 mm +/- 0.1
Cable material	PVC
Measurement range	-10 .. 70° C
Cable length	Standard 2 metres
Protection type	IP 65

Sensors other than our standard type are available on request (different bush from or cable length).

Some of the options are shown here.

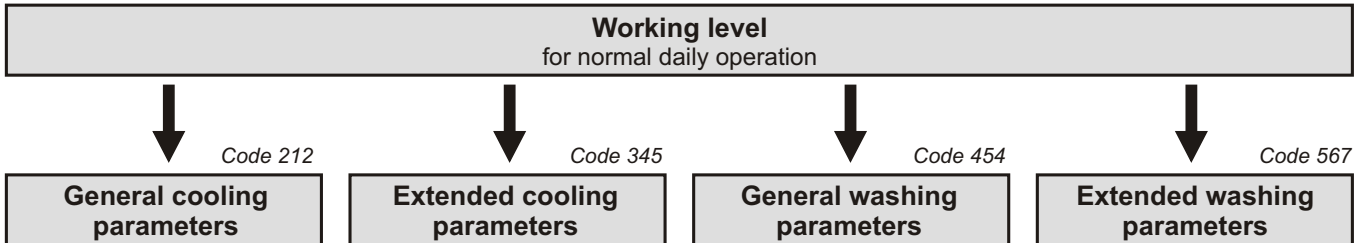

Operation of the WTS-100-2 takes place at various levels:

### **Working level:**

... for normal daily operation.

- OFF mode = control unit switched off.
- Start cooling mode.
- Start continuous stirring mode.
- Start washing mode.

**The subsidiary parameters are accessed by entering a code in order to avoid their accidental alteration.**

### **General cooling parameters**

Parameters such as target values, hysteresis etc. are set here.

### **Extended cooling parameters**

For programming the control unit's individual tank-specific cooling functions.

### **General washing parameters**

Parameters such as times are set here.

### **Extended washing parameters**

For programming the control unit's individual tank-specific washing functions.

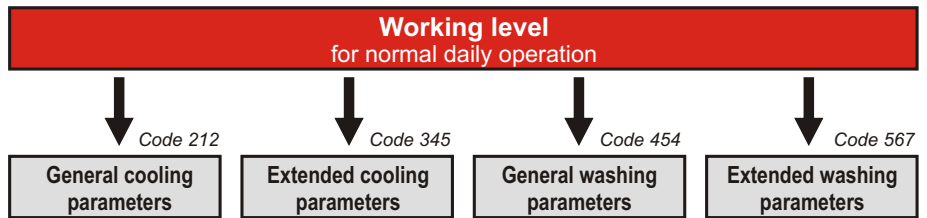

The working level is for normal daily milk-cooling operation. In cooling mode, the current milk temperature as measured is permanently displayed.

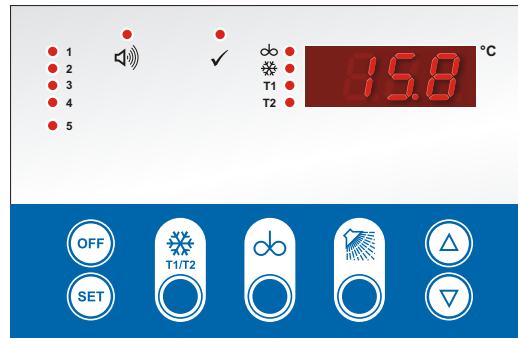

## Button functions

To change to a different mode always press the 'OFF' button first.

Active modes are closed down by pressing the 'OFF' button.



### OFF button

- Switch regulator to STANDBY
- Switch off continuous stirring
- Acknowledge error
- Switch to programming mode (press button for 3 seconds)



### SET button

in working level without function

Press COOLING twice to cancel the delayed start to cooling



### COOLING button

- in OFF mode = Start cooling
- press twice = Bypass coolingstart delay.
- in cooling mode = Switch between target temperatures T1/T2



### AGITATOR button

- in OFF mode = Continuous stirring
- in cooling mode (press 1 sec.) 'Intermediate stirring SHORT'
- in cooling mode (press 3 sec.) 'Intermediate stirring LONG'

See also section:

**'Intermediate stirring options' on page 30.**



### WASHING button

- in OFF mode = Start washing



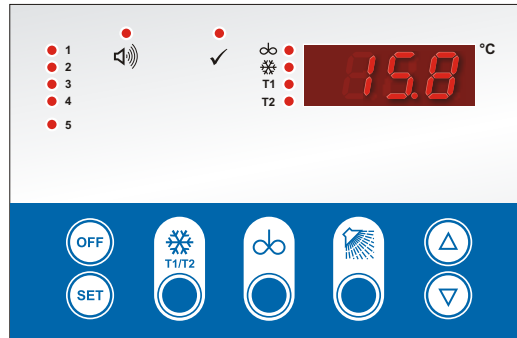

## 1) OFF mode (tank empty)

The control unit is on stand-by. The display shows 'OFF', the LEDs are out. All output relays are deactivated.

The following operating modes can only be selected from OFF mode and it is not possible to switch directly between them.

**CAUTION: The control unit is live even when switched off.**



## 2) Cooling mode

### MANUAL starting of cooling

- Press "COOLING" button on foil keyboard in OFF-mode:
  - LED 'T1' or 'T2' lights up (for target temperature 1 or 2). If the target temperature set is briefly displayed then the current temperature of the medium is shown.  
If the other target temperature is preferred, press the 'COOLING' button again (the switchover option from T1 to T2 can be blocked via parameter [P80] ).
  - If 'Cooling start delay' [c80] is programmed cooling will not start immediately. During the delay the compressor LED blinks. Press the 'COOLING' button twice in succession to start cooling without a delay.
  - The milk will now be cooled to the set target temperature. The agitator motor runs continuously. If the milk temperature is already lower than the target temperature only the agitator operates.
  - When the target temperature is reached the compressor switches off.
  - The agitator switches off at the end of the 'after-stirring' time [c20].
  - During cooling pauses the agitator switches on periodically: in accordance with the 'pause time' set [c21], for the duration of the 'after-stirring' time [c20], in order to ensure an even temperature throughout the milk.
  - If the milk temperature exceeds the selected target temperature by the set 'hysteresis' value [c10 or c11] the compressor and agitator automatically start again.

*if present:*

**Washing can be started only if the safety switch for the tank outlet is open.**

*Only relevant if parameter [n50] is set to 1*

### **DIRECT START digital starting of cooling**

- Start cooling via digital input – Direct start
  - As described previously. (See page 3)



*Stirring in cooling mode = INTERMEDIATE STIRRING*

- Briefly press 'AGITATOR' in cooling mode:
    - A short intermediate stirring period [duration = c50] is triggered.
  - Press 'AGITATOR' in cooling mode for around 5 seconds:
    - A long intermediate stirring period [duration = c51] is triggered.
- See also the section: 'Intermediate stirring options' on page 30.



### **3) Continuous stirring mode**

*if parameter [c85] = '0'*

- Press 'AGITATOR' button in OFF mode:
  - Switches on continuous stirring (rotating symbol in display).
- Press 'OFF' button:
  - Switches off continuous stirring.

*if parameter [c85] > '0'*

- Press 'AGITATOR' button in OFF mode:
  - If parameter [c85] is set to > '0', once the button has been pressed the agitator runs for the set number of minutes.



### **4) Washing mode**

- Press 'WASHING' button in OFF mode:
  - The washing programme runs automatically. The current washing stage (there are up to five) is indicated by LED.
  - The agitator always operates at the same time as the washing pump.
  - Relay K10 is activated for the entire washing process.

*if present:*

**Washing can be started only if the safety switch for the tank outlet is open.**

*Only relevant if parameter [n50] is set to 1*

# Washing programme description

## Washing programme diagram

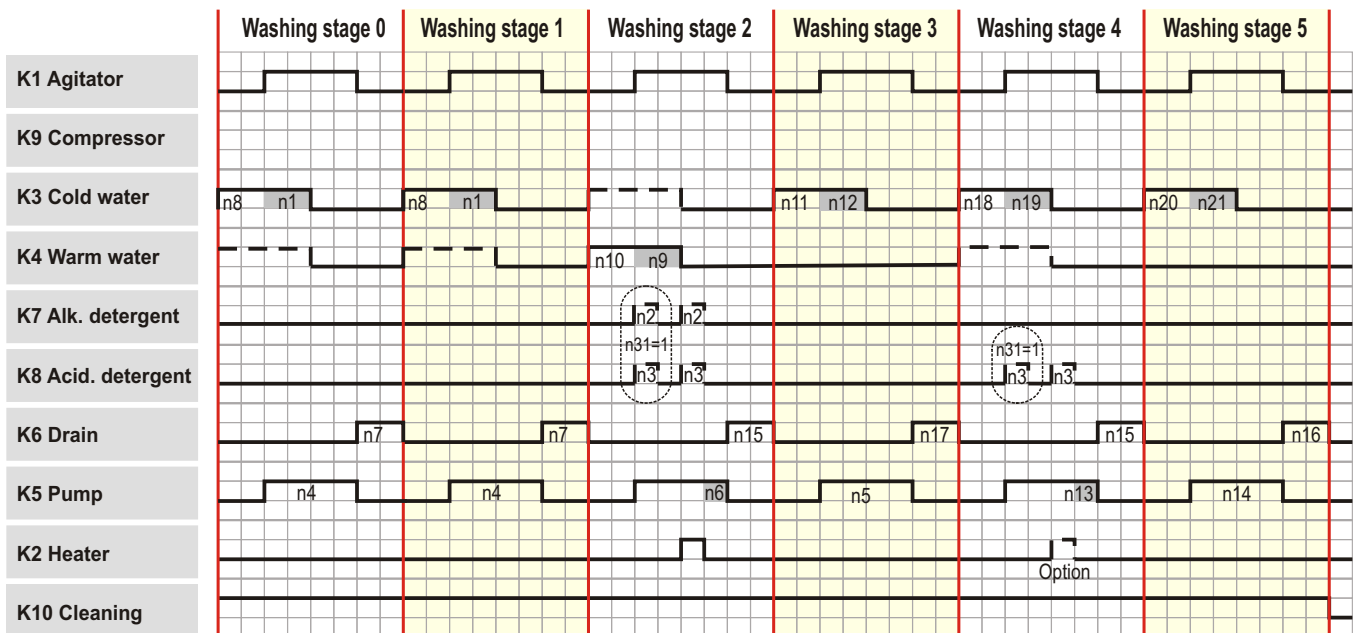

broken lines: only applicable if activated through parameters.

The "n" designations represent the parameters which can be used to adjust the corresponding times.

See page 25 for adjustment of n-parameters.

A washing cycle consists of up to six different washing stages. The frequency of each stage during a cycle can be set by the user.

See parameter [n23 to n28].

### Washing stage 0 (LED 1): PRE-RINSE

Parameter [n23] = 0 'Wash stage 0' deactivated

Parameter [n23] = 1..10 Run 'wash stage 0' n times

- Water is taken in.

The washing parameter [r49] is used to stipulate whether cold, hot or mixed water is to be taken in.

It is also stipulated for all stages [r30] whether water is to be taken in by 'level' or by 'time' [n8].

*If, in the event of intake by level, the level is not reached after a pre-set time, the washing cycle is interrupted. See fault description.*

- Agitator and pump start to run.

The water circulates for the pre-set time [n4].

*Another option is to select an 'additional water intake time' using parameter [n1].*

- Agitator and pump switch off.

- Outlet valve opens for the pre-set time [n7].

Parameter [r60] is used to determine whether the drain valve is normally open or closed. Applies for all washing stages.

### Washing stage 1 (LED 1): PRE-RINSE

Parameter [n24] = 0 'Wash stage 1' deactivated

Parameter [n24] = 1..10 Run 'wash stage 1' n times

- Water is taken in (by level or time, as described in washing stage 1.) The washing parameter [r50] is used to stipulate whether cold, hot or mixed water is to be taken in.

*If, in the event of intake by level, the level is not reached after a pre-set time, the washing cycle is interrupted.*

*See fault description.*

#### Information regarding relay K10: Washing

The relay serves to cancel milking authorisation for milking robots that are connected.

When washing starts (regardless of the stage), relay K10 is switched on and remains activated until the end of the washing programme.

The relay also remains activated if the control system switches to error mode. Only when the error is acknowledged manually does the relay switch off.

- Agitator and pump start to run.  
The water circulates for the pre-set time [n4].  
*Another option is to select an 'additional water intake time' using parameter [n1].*
- Agitator and pump switch off.
- Outlet valve opens for the pre-set time [n7].

### Washing stage 2 (LED2): MAIN WASH 1

- Parameter [n25] = 0      'Wash stage 2' deactivated
- Parameter [n25] = 1..10      Run 'wash stage 2' n times
- Water is taken in (by level or time, as described in washing stage 1.) If water intake is controlled by 'time', parameter [n10] applies here. Parameter [r51] is used to stipulate whether cold, hot or mixed water is to be taken in
- Agitator and pump start to run. The water circulates in the tank.
- Another option is to select an 'additional water intake time' using parameter [n9].
- If a heater is fitted [parameter r40' yes/no], it is switched on after period [n9].  
*If, when hot water enters, the tank is still cold from the previous cooling operation, the water can cool down quickly. To prevent the heater switching off too soon the temperature is not measured until three minutes after the start of heating.*
- Depending on the setting of the parameter [n31], detergent is injected at the end of the water intake time [n10] or the subsequent water intake time [n9] as follows:  
*If 'Wash 4' is operational (parameter n27 > 0) only alkaline detergent is injected here for duration [n2].*  
*If 'Wash 4' is deactivated (parameter n27 = 0) alternately alkaline detergent is injected for duration [n2] or acidic detergent is injected for duration [n3]. See also parameter [n30].*
- Once the heating temperature is reached [n40] the heater switches off.  
*If the temperature is not reached within the pre-set time [r42], the control unit continues with the programme, but a fault report is displayed at the end. See fault description.*
- The water circulates for the pre-set time [n6].
- Agitator and pump switch off.
- Outlet valve opens for the pre-set time [n15].

### Washing stage 3 (LED3): INTERMEDIATE RINSE

- Parameter [n26] = 0      'Wash 3' deactivated
- Parameter [n26] = 1..10      Run 'Wash3' n times
- Cold water is taken in (by level or time, as described in washing stage 1.) If 'time-controlled' the time period is set by [n11].
- Agitator and pump start to run.  
The water circulates for the pre-set time [n5].
- Another option is to select an 'additional water intake time' using parameter [n12].
- Agitator and pump switch off.
- Outlet valve opens for the pre-set time [n17].

### Washing stage 4 (LED4): MAIN WASH 2

Parameter [n27] = 0 'Wash 4' deactivated

Parameter [n27] = 1..10 Run 'Wash 4' n times

- Water taken in.  
Parameter [r52] is used to determine whether cold, hot or mixed water is taken in.  
If water intake is regulated by time, parameter [n18] applies.
- Agitator and pump start to run. The water circulates in the tank.
- Another option is to select an 'additional water intake time' using parameter [n19].
- If a heater is fitted [parameter r41' yes/no] it is switched on after period [n19].  
*If, when hot water enters, the tank is still cold from the previous cooling operation, the water can cool down quickly. To prevent the heater switching off too soon the temperature is not measured until three minutes after the start of heating.*
- Depending on the setting of the parameter [n31], acidic detergent is injected at the end of the water intake time [n18] or the subsequent water intake time [n19] for the period [n3].
- Once the heating temperature is reached [n41] the heater switches off.  
*If the temperature is not reached within the pre-set time [r42], the control unit continues with the programme, but a fault report is displayed at the end. See fault description.*
- The water circulates for the pre-set time [n13].
- Agitator and pump switch off.
- Outlet valve opens for the pre-set time [n15].

### Washing stage 5 (LED5): FINAL RINSE

Parameter [n28] = 0 'Wash 5' deactivated

Parameter [n28] = 1..10 Run 'Wash 5' n times

- Cold water is taken in (by level or time, as described in washing stage 1. If 'time-controlled' the time period is set by [n20].
- Agitator and pump start to run.  
The water circulates for the pre-set time [n14].
- Another option is to select an 'additional water intake time' using parameter [n21].
- Agitator and pump switch off.
- Outlet valve opens for the pre-set time [n16].

If the washing programme has run without fault the control unit automatically switches to 'OFF mode'. ('OFF' is displayed and the LED ✓ 'END' lights up.) Any other mode can now be selected.

### Faults during washing

*Information regarding relay K10:  
Washing*

*The relay serves to cancel milking authorisation for milking robots that are connected.*



*When washing starts (regardless of the stage), relay K10 is switched on and remains activated until the end of the washing programme.*

*The relay also remains activated if the control system switches to error mode. Only when the error is acknowledged manually does the relay switch off.*

General principle:



To acknowledge the fault report press the 'OFF button' for 3 seconds. 'OFF' is displayed and the LED 'Washing END' lights up. Any other mode can now be selected.

■ *Washing temperature not reached:*

- The washing programme continues to the end.
- At the end of the washing programme:
  - a flashing fault report 'F04' is displayed
  - the LED  'FAULT' blinks
  - the LED  'Washing END' lights up.



The control unit is in fault mode which has to be cancelled.

■ *The digital input for the safety switch [n50=1] for the tank outlet is triggered (contact opens):*

- Washing stops.
- The outlet valve is opened for time [n 16].
- The programme LED for this stage blinks.
- The display alternates between 'OFF' and the current temperature.
- After time [n 16]:
  - the outlet valve closes
  - a flashing fault report 'F03' is displayed
  - the LED  'FAULT' blinks
  - the LED  'Washing END' lights up.

The control unit is in fault mode which has to be cancelled.

■ *Time for water intake by level exceeded:*

- Washing stops.
- The outlet valve is opened for time [n 16].
- The programme LED for stage 5 blinks.
- After time [n 16]:
  - the outlet valve closes
  - a flashing fault report 'F14' is displayed
  - the LED  'FAULT' blinks
  - the LED  'Washing END' lights up.

The control unit is in fault mode which has to be cancelled.

- *Washing is stopped manually by using the OFF button:*
  - Washing stops.
  - The outlet valve is opened for time [n29] (pressing the OFF button again ends the waiting time [n29]).
  - The programme LED for this stage blinks.
  - The display alternates between 'OFF' and the current temperature.
  - After time [n29]
    - the outlet valve closes
    - the control unit switches to OFF mode
    - the LED ✓ 'Washing END' lights up.
  
- *When power is restored after an outage:*
  - The outlet valve is opened for time [n 16].
  - The current temperature is displayed.
  - After time [n 16]
    - the outlet valve closes
    - the control unit continues the washing programme from the start of the stage it was in when power was lost.

### **For installation and service purposes**

- For installation and service purposes the control unit can be started at any desired washing stage. The adjustment for this is done in the service parameter level [r35]. If the cleaning once was started from the selected rinse process it starts afterwards automatically again with the rinse process which is selected in the n-parameter.
- All inputs and outputs for the individual tank components can be tested in the parameter level. To this end the corresponding relays are set to '1' or '0'. However, the two relays for the addition of acidic and alkaline detergent are locked against each other, acidic and alkaline detergents must never be in the tank at the same time.

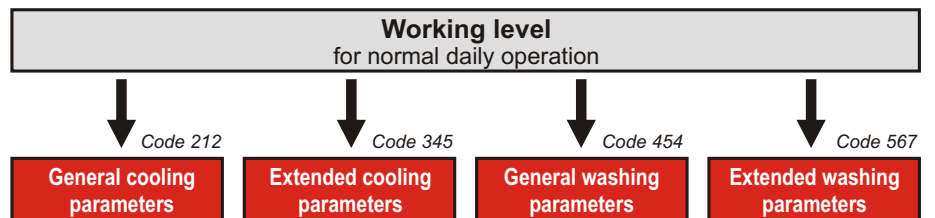

### Enter level codes:

In order to change parameters in one of the lower levels enter the appropriate level code.

General cooling parameters . . . . . Code 212  
Extended cooling parameters . . . . . Code 345  
General washing parameters. . . . . Code 454  
Extended washing parameters . . . . . Code 567

Proceed as follows (control unit must be in OFF mode):

- Press 'OFF' button for 3 seconds:  
'000' appears in the display - the first '0' blinks.
- Use the ▲/▼ buttons to select the first digit of the required code
- Confirm the correct digit by pressing 'SET'.  
The digit is accepted and the second '0' blinks.
- Use the ▲/▼ buttons to set the second digit
- Confirm the correct digit by pressing 'SET'.  
The third '0' blinks.
- Use the ▲/▼ buttons to set the third digit
- Confirm the correct digit by pressing 'SET'.  
The first parameter of the selected level now appears.

If an incorrect code is entered the control unit switches back into OFF mode.

### Display parameter value:

- Use the ▲/▼ buttons to select the desired parameter.
- Press the 'SET' button: the parameter value is displayed.

### Change parameter value:

- Use the ▲/▼ buttons to select the desired parameter.
- Hold down the 'SET' button and use the ▲ or ▼ button to select the desired value. (Hold down the arrow buttons to move more quickly).  
In order to store the value release the ▲ or ▼ button first, then the 'SET' button.

### Return to working level:

(possible from any parameter)

- Press UP and DOWN buttons simultaneously for approx. 5 seconds. The current actual value is displayed. (If no buttons are pressed for 60 seconds the control automatically switches back to the working level. Attention: Any changes will not be accepted!)

## C-parameters

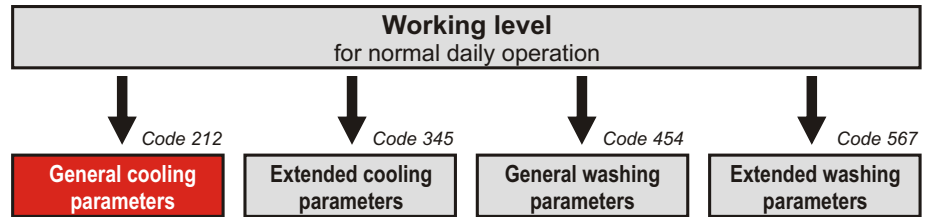

### Switch to 'General cooling parameters' level

- See page 20.

### Meaning of parameters

**c1 target temperature for T1** (default 8°C)

**c2 target temperature for T2** (default 4°C)

The target temperature is the temperature to which the milk is to be cooled down. When the target temperature is reached the compressor switches off. See diagram.

Range in each case -10 to 99.9°C

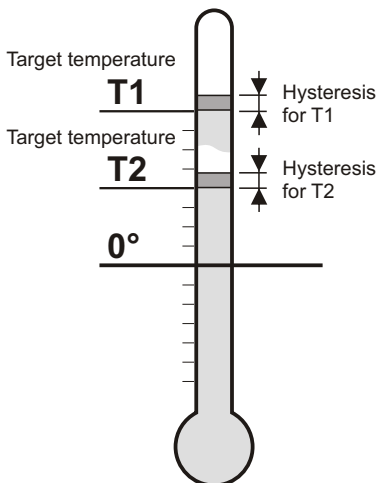

**c10 Hysteresis for target temperature 1** (default 0,7 K)

**c11 Hysteresis for target temperature 2** (default 0,7 K)

The hysteresis determines the amount by which the milk temperature is allowed to differ from target temperature T1 or T2 before the cooling compressor is switched on again. See diagram.

Range in each case 0.1 to 10K

**c20 Duration of after-stirring** (default 120 seconds)

Period in seconds for which the agitator continues to operate after the compressor is switched off.

Range 0 to 999 seconds.

**c21 Pause duration** (default 20 minutes)

Period in minutes between agitator switching off and switching on again (for the duration of the after-stirring period selected).

Range 0 to 999 minutes.

**c50 Duration of 'intermediate stirring SHORT'** (default 2 minutes)

Period in minutes during which the agitator operates if the UP arrow button is pressed for approx. 1 second during a cooling pause.

Range 0 to 999 minutes.

**c51 Duration of 'intermediate stirring LONG'** (default 10 minutes)

Period in minutes during which the agitator operates if the UP arrow button is pressed for approx. 3 seconds during a cooling pause.

Range 0 to 999 minutes.

- c79 Changeover delayed start cooling switch for remote start:**  
(default 0)  
0 = without delayed start cooling  
1 = with delayed start cooling
- c80 Delayed start to cooling for first milking** (default 0 minutes)  
Delay in minutes between the "Cooling" button is being pressed and the compressor is starting. The 'Compressor' LED blinks during this period. All subsequent cooling cycles start without a delay.  
Range 0 to 999 minutes.
- c81 Maximum cooling time for first milking** (default 0 minutes)  
The active target temperature must be reached within the set time otherwise a fault report [F15] appears in the display.  
Set to '0' to deactivate this function.  
Range 0 to 999 minutes.
- c85 Maximum continuous stirring period** (default 30 min.)  
Setting of maximum continuous stirring period.  
0 = indefinite stirring  
(to end, the OFF button must be pressed)  
1..999 = max. stirring period in minutes
- c90 Display actual temperature**  
The present actual value measured by the sensor is shown.
- c91 Sensor correction**  
A correction can be applied to the value measured by the sensor. Then applies it cumulatively throughout the entire measurement range.  
See page 31.  
Range -10 to 10K
- c98 Installed software version**  
The software version installed is shown to help service technicians.

## P-parameters

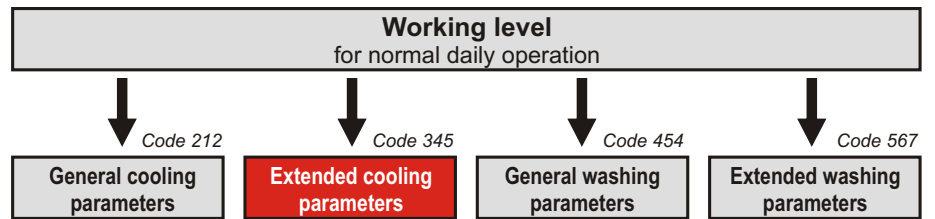

### Switch to level 'Extended cooling parameters'

- See page 20.

### Meaning of parameters

**P5 Relay function K1 (agitator) in the event of sensor fault** (default 2)

**P6 Relay function K9 (compressor) in the event of sensor fault** (default 2)

The switching status of the relay contacts K1 and K9 is adjustable for the event of a fault.

0 = in case of fault 'OFF'

1 = in case of fault 'ON'

2 = no influence

**P20 Lower limit for target temperature T1** (default 2°C)

**P21 Upper limit for target temperature T1** (default 20°C)

**P22 Lower limit for target temperature T2** (default 2°C)

**P23 Upper limit for target temperature T2** (default 20°C)

Setting (via keyboard) of limitations for target temperatures in working and adjustment level.

Range -10 to 99°C

**P30 Lower limit for hysteresis T1** (default 0,1 K)

**P31 Upper limit for hysteresis T1** (default 2 K)

**P32 Lower limit for hysteresis T2** (default 0,1 K)

**P33 Upper limit for hysteresis T2** (default 2 K)

Setting (via keyboard) of limitations for hysteresis in the adjustment level.

Range 0 to 99K

**P70 Minimum cooling time for compressor K1** (default 0 min.)

Setting of minimum running time for compressor, to prevent output relay K1 switching on and off too frequently.

Range 0.0 to 999 min.

**P71 Minimum pause time for compressor K1** (default 0 min.)

Setting of minimum pause time for compressor to prevent output relay K1 switching on and off too frequently.

Range 0.0 to 999 min.

**P80 Switchover from T1 to T2** (default 1)

Setting of 'Switch target temperature' function

0= not possible (target temperature T1 always active)

1= via keyboard (standard, switchover via foil keyboard)

**P81 'Intermediate stirring' function** (default 1)

Setting of 'intermediate stirring' function.

See also section 'Intermediate stirring' options' on page 30.

0 = Intermediate stirring not possible

1 = Standard setting

(Switch on intermediate stirring 'short' or 'long' using buttons)

2 = Continuous stirring ON/OFF

(press the button once to switch the agitator on, press again to switch it off)

## n-parameters

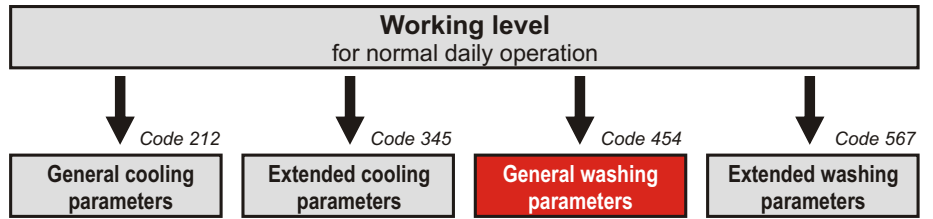

### Switch to level 'General washing parameters'

- See page 20.

### Meaning of parameters

#### n1 Additional water intake time in washing stage 0 + 1

Range 0-600 seconds  
Factory setting 20 seconds

#### n2 Intake time for alkaline detergent in washing stage 2

Range 0-600 seconds  
Factory setting 30 seconds

#### n3 Intake time for acidic detergent in washing stage 4 (or 2)

Range 0-600 seconds  
Factory setting 30 seconds

#### n4 Circulation time in washing stage 0 + 1

Range 0-300 seconds  
Factory setting 30 seconds

#### n5 Circulation time in washing stage 3

Range 0-300 seconds  
Factory setting 30 seconds

#### n6 Circulation time in washing stage 2

Range 0-600 seconds  
Factory setting 60 seconds

#### n7 Drain time (outlet valve open) in washing stage 0 + 1

Range 0-999 seconds  
Factory setting 60 seconds

#### n8 Water intake time in washing stage 0 + 1 (or by level)

Range 0-600 seconds  
Factory setting 30 seconds

#### n9 Additional water intake time in washing stage 2

Range 0-600 seconds  
Factory setting 20 seconds

- n10 Water intake time in washing stage 2** (or by level)  
Range 0-600 seconds  
Factory setting 40 seconds
- n11 Water intake time cold water in washing stage 3** (or by level)  
Range 0-600 seconds  
Factory setting 40 seconds
- n12 Additional water intake time for cold water in washing stage 3**  
Range 0-300 seconds  
Factory setting 20 seconds
- n13 Circulation time in washing stage 4**  
Range 0-600 seconds  
Factory setting 120 seconds
- n14 Circulation time in washing stage 5**  
Range 0-300 seconds  
Factory setting 60 seconds
- n15 Drain time in washing stage 2 / 4**  
Range 0-999 seconds  
Factory setting 90 seconds
- n16 Drain time in washing stage 5**  
Range 0-999 seconds  
Factory setting 120 seconds
- n17 Drain time in washing stage 3**  
Range 0 - 999 seconds  
Factory setting 90 seconds
- n18 Water intake time in washing stage 4** (oder über Niveau)  
Range 0 - 999 seconds  
Factory setting 120 seconds
- n19 Additional water intake time in washing stage 4**  
Range 0 - 999 seconds  
Factory setting 0 seconds
- n20 Water intake time cold water washing stage 5** (oder über Niveau)  
Range 0 - 999 seconds  
Factory setting 120 seconds
- n21 Additional water intake time cold water in washing stage 5**  
Range 0 - 999 seconds  
Factory setting 0 seconds
- n23 Number of wash 1 operations**  
Range 0 .. 10  
Factory setting 0
- n24 Number of wash 1 operations**  
Range 0 .. 10  
Factory setting 1
- n25 Number of wash 2 operations**  
Range 0 .. 10  
Factory setting 1

**n26 Number of wash 3 operations**

Range 0.. 10

Factory setting 1

**n27 Number of wash 4 operations**

Range 0.. 10

Factory setting 1

**n28 Number of wash 5 operations**

Range 0.. 10

Factory setting 1

**n29 Water drainage time when washing is interrupted manually**

Range 0.. 999 sek.

Factory setting 150 sek.

**n30 Detergent injection sequence**

Active only if parameter [n27] = '0'

To set the number of alkaline washes after which an acidic wash will take place.

0 = alk - alk - alk - acid.

1 = alk - alk - acid.

2 = alk - acid.

Factory setting 0

**n31 Detergent injection time**

Choice of whether detergent is injected at the end of the water intake time (n9 / n19) or the subsequent water intake time (n10 / n18).

The cleaning diagram on page 15 shows the factory setting 0.

0 = detergent injection at the end of the subsequent water intake time (n9 / n19)

1 = detergent injection at the end of the water intake time (n10 / n18)

Factory setting 0

**n40 Heating temperature in washing stage 2**

Range 0°-70°C

Factory setting 53°C

**n41 Heating temperature in washing stage 4**

Range 0°-70°C

Factory setting 45°C

**n50 Safety switch present, yes / no (default 1)**

0 = NO

1 = YES

## r-parameters

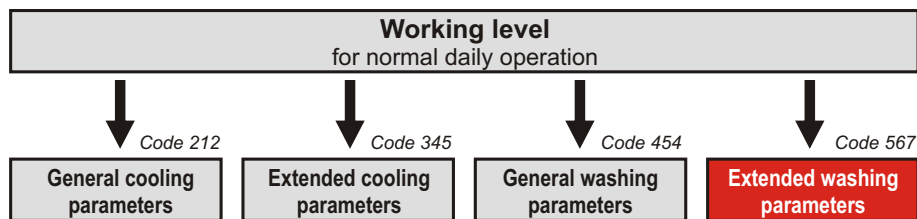

### Switch to level 'Extended washing parameters'

- See page 20.

### Meaning of parameters

<b>r1</b>	<b>Test relay output 1</b>	(agitator)
<b>r2</b>	<b>Test relay output 2</b>	(heater)
<b>r3</b>	<b>Test relay output 3</b>	(cold water valve)
<b>r4</b>	<b>Test relay output 4</b>	(hot water valve)
<b>r5</b>	<b>Test relay output 5</b>	(washing pump)
<b>r6</b>	<b>Test relay output 6</b>	(outlet valve)
<b>r7</b>	<b>Test relay output 7</b>	(alkaline 'detergent pump')
<b>r8</b>	<b>Test relay output 8</b>	(acidic 'detergent pump')
<b>r9</b>	<b>Test relay output 9</b>	(compressor)
<b>r10</b>	<b>Test relay output 10</b>	(cleaning activ)

For testing the relay contacts.

On leaving this level all outputs are automatically returned to '0'.

0 = Relay switched off

1 = Relay active

**r12 Test digital input 'safety switch'**

**r13 Test digital input 'level'**

**r14 Test digital input 'external cooling start'**

The SET button can be used to check the switching status of the digital inputs. No values can be entered here.

0 = input not connected

1 = input connected

**r30 Water intake by level or time** (default 0)

0 = Level

1 = Time

**r31 Max. water intake time for intake by level** (then stop) (default 10 min.)

Range 0-60 minutes (0 = not monitored)

**r35 Start in washing stage 'X'** (default 1)

*only for technician:*

The next wash will start with the selected washing stage. Afterwards you start again with the rinse process which has been selected as starting rinse process in the n-parameter.

Range: 1 - 5

**r40 Heating in washing stage 2** (default 1)

0 = NO  
1 = YES

**r41 Heating in washing stage 2** (default 0)

0 = NO  
1 = YES

**r42 Max. heating time** (default 60 minutes)

If the target temperature for the water is not reached within the set time washing continues and a fault report [F04] is displayed at the end.

Range: 15 - 999 min.

**r49 Water intake in washing stage 0** (default 1)

**r50 Water intake in washing stage 1** (default 1)

**r51 Water intake in washing stage 2** (default 0)

**r52 Water intake in washing stage 4** (default 0)

0 = hot water only  
1 = cold water only  
2 = mixed water (hot and cold)

**r60 outlet valve function (default 0)**

Choice of whether the outlet valve used should be closed or open when de-energised. The control unit acts according to the setting

0 = de-energised: closed (normal function)  
1 = de-energised: open



The universal tank control WTS-100-2 has a function allowing the agitator to be switched on manually. This can be done in different ways.

Regardless of the chosen option the corresponding LED always indicates when the agitator is operating.

The function is set at configuration level using parameter [r81].

*Adjustment of P parameter  
see page 21.*

### **Parameter [r81] is set to 0:**

"Intermediate stirring" is not possible.

### **Parameter [P81] is set to 1 (standard):**

"Intermediate stirring SHORT or LONG" can be switched on via the regulator's foil keyboard. In this case:

- Intermediate stirring SHORT = Press agitator button for approx. 1 sec. until "Sho" appears in the display. Release the button immediately - otherwise "Intermediate stirring LONG" will be activated.
- Intermediate stirring LONG = Press agitator button for approx. 3 secs. until "Lon" appears in the display.

### **Parameter [P81] is set to 2:**

Function: Continuous stirring ON / OFF

By pressing the button the agitator is switched on and can be switched off by pressing the OFF-button.

## "Continuous stirring" function

Continuous stirring is started by pressing the "Agitator" button in OFF-mode.

*if parameter [c85] = '0'*

Pressing the "OFF" button stops continuous stirring.

*if parameter [c85] > '1 .. 999'*

The agitator stops automatically after the set time.

A rotating bar appears in the display during continuous stirring.

## Setting the actual value correction

A correction can be made to the value as measured by the sensor, which applies cumulatively over the entire measuring range.

This is necessary when:

- the length of the sensor cable is changed or
- a faulty sensor is replaced - giving rise to an incorrect reading.



*Adjustment of c-parameter  
see page 21.*

In order to adjust the actual value correction a reference thermometer (e.g. WELBATHM-2000) is needed.

Proceed as follows:

- Install sensor.
- Measure the temperature of the medium using the reference thermometer.
- Switch on the thermostat and set parameter [C91] in the programming level to "0".
- Switch back to working level and read the measured temperature on the display.
- Calculate the difference between the reference thermometer temperature and the display reading.
- Store the difference (pay attention to plus or minus) in the working level under parameter [C91].

## Adjustment of level control

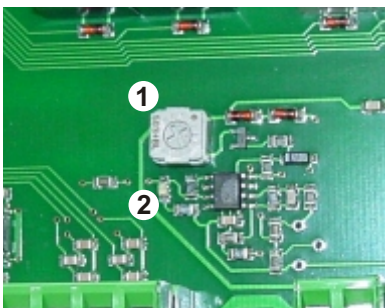

The level control is factory-set to 'medium' water quality. Depending on the hardness of the local water supply the sensitivity can be adjusted on a potentiometer as follows:

- Turn potentiometer 1 to the right to increase sensitivity
- Turn potentiometer 1 to the left to reduce sensitivity

'Level OK' is indicated by LED 2.



Faults in the regulator are indicated by a flashing display as follows:

LED - Display	Faults
<b>F03</b>	<b>Digital input for tank outlet safety switch triggered</b> See page 18.
<b>F04</b>	<b>Heating duration too long</b> If the target temperature for the water is not reached within the set time, washing continues and a fault report [F04] is displayed at the end. The time is set in the 'Extended washing parameters' level under [r42].
<b>F05</b>	<b>Broken sensor:</b> The sensor or sensor cable is faulty and must be replaced or repaired. Parameter [C91] 'Actual value correction' must then be adjusted at Programming level. See page 31.
<b>F06</b>	<b>Sensor short circuit:</b> The sensor or sensor cable is faulty and must be replaced or repaired. Parameter [C91] 'Actual value correction' must then be adjusted at Programming level. See page 28.
<b>F12</b>	<b>Safety switch fault</b> Safety switch not set to 'Cooling' or 'Washing'
<b>F14</b>	<b>No water</b> Fault occurs when the level is not reached during the set water intake time. See page 18.
<b>F15</b>	<b>Cooling time exceeded</b> The active target temperature must be reached within the set time, otherwise a fault report [F15] is displayed. See page 22.
<b>F99</b>	<b>Memory fault:</b> Faulty regulator! Remove the regulator and send it for repair.
<b>FFF</b>	<b>Measurement range for sensor 1 exceeded</b> The sensor fitted can only measure temperatures between -50° and +150°C.

So that even complicated regulatory tasks can be presented to the user in a manner which is clear and simple and ensures high measurement accuracy, today's electronic control systems make increasing use of microprocessors. However, the benefits of these systems are countered by the disadvantage that increased measurement accuracy is accompanied by sensitivity to interference. In order to minimise the effect which interference may have on the regulator the user also must take account of a number of points when installing a new regulator.

Assistance here is provided by standard DIN VDE 0843 on the electromagnetic compatibility (EMC) of measurement, control and regulatory devices in industrial process technology. The following table shows, for example, the maximum interference levels to which (according to the standard), an appliance may be exposed.

<i>Degree of severity</i>	<i>Environment class</i>	<i>Test voltage Power supply</i>	<i>Test voltage Signal/control line</i>
1	well-protected environment	0.5 kV	0.25 kV
2	protected environment	1.0 kV	0.5 kV
3	typical industrial environment	2.0 kV	1.0 kV
4	industrial environment with very high interference level	4.0 kV	2.0 kV

As the values given in the table are maximum values, operational values should remain well below them. However, in practice this is possible only with difficulty, as even a normal contactor without interference suppression produces interference pulses of up to 3.0 kV. For this reason we recommend that the following principles be taken into account during installation:

- a. Try to eliminate all sources of interference by carrying out interference suppression and minimising the interference level. Radio interference suppression is required under VDE 0875 and confirmed by VDE 0874. In principle the interference must be eliminated at source. The nearer the interference suppresser is to the source of interference the greater its effect.

Interference spreads through wires or by electromagnetic radiation. It is usually the former which interferes most seriously with regulation systems.

Possible interference sources (to name a few) include:

- bouncing contacts when switching loads
- switching off inductive loads (contactors, motors, solenoid valves, etc.)
- unsatisfactory routing of wires, too small cross-sections
- loose contacts
- rhythmically changing power stages (power converters)
- power breakers
- high-frequency generators

- b. If specific interference sources cannot be avoided they should at least be kept at a distance from the regulator system.
- c. Capacitive and inductive couplings can cause crosstalk between high-voltage lines and parallel low-voltage and sensor lines. This distorts measured values and signals and can disrupt the entire regulatory process. It is therefore recommended that all sensors and signal lines be placed separately from the control and mains voltage lines.
- d. If possible a separate main line should be provided to feed the regulator system. This helps reduce any interference penetrating the regulator via the mains supply line. Voltage surges resulting from switching substantial loads will also then be less of a problem.
- e. In the case of contactors, solenoid valves and other inductive consumers the induction voltage occurring during switching has to be reduced by appropriate protection methods. The choice of methods depends on whether the consumer runs on DC or AC voltage.

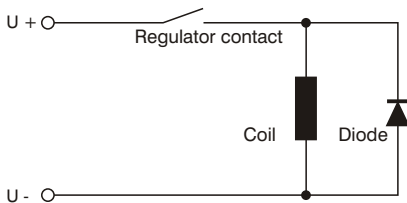

- *DC voltage*

In the case of d/c voltage systems the induction voltage occurring can, for example, be limited by using self-induction diodes, varistors or suppresser diodes. The diagram on the left shows one possibility using a self-induction diode.

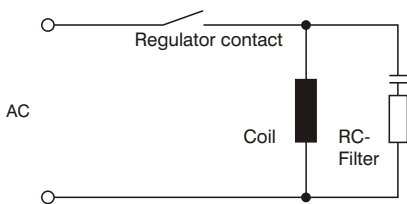

- *AC voltage*

In the case of a/c voltage interference suppression as described above is not possible. Instead an RC combination must be used. An RC filter must be connected as directly as possible to the inductance in order to ensure a short line. In addition the component ratings of the RC combination must be geared to the inductance. Too low ratings lead to excessive voltage and too high ratings cause significant losses in the interference suppresser component. Another point to note here is that only capacitors which meet VDE 0656 may be used. They must be suited to the mains voltage and designed for very high switching voltages. The diagram on the left shows inductance interference suppression using an RC filter.

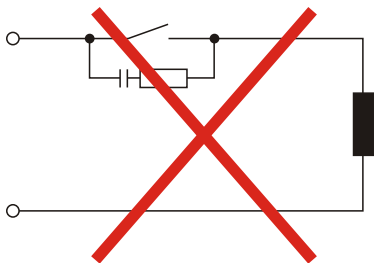

An RC filter should not be fitted directly to the regulator's switching contact (as shown on the left), as an idle current will flow through the RC combination even when the switching contact is open. This current may be enough to mean that a downstream contactor is not de-energised and a closed protective contact does not reopen.

- f. Semiconductor switches such as thyristors or triacs also produce interference voltages. They occur as a result of non-linear characteristics and finite ignition voltages. These components must be protected against excessive voltages, for which mainly varistors, RC combinations or choke coils are used. The use of zero-voltage switches is also recommended.

The suggestions made represent only a few of the possible ways of protecting a microprocessor-controlled regulator system from interference. The suggested measures have the advantage that they will increase the lifetime of the devices as lower induction voltages (reduced spark formation) will also reduce contact burn.

# Circuit diagram WTS-100-2-A G1

